

LEXICON

INSTALLATION INSTRUCTIONS: LEXICON - SEATS, LEGS, BACKS AND MODULES

DWG: INST_LXM1500-SS

REV: M01

SEAT TO LEG (PG 3)

NOTE THE PRINCIPLES FOR THE SEAT TO LEG ASSEMBLY APPLY TO ALL LEG STYLES AND BOTH THE CURVED AND STRAIGHT SEAT SECTIONS

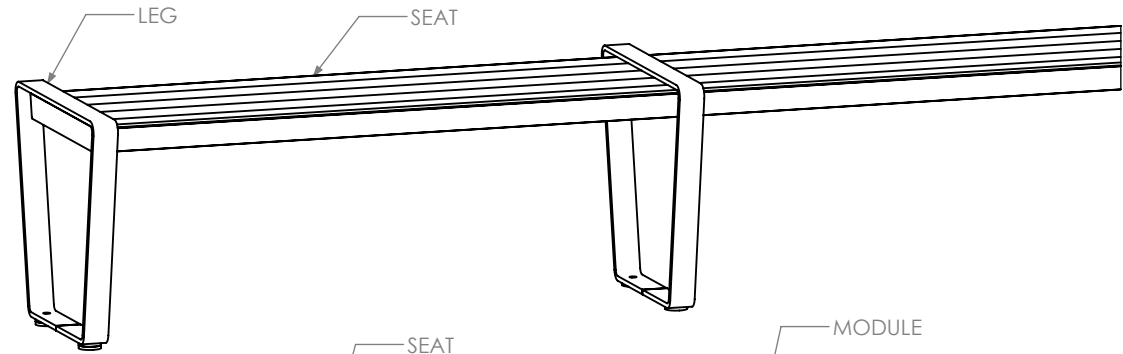

SEAT TO MODULES (PG 7)

NOTE THE PRINCIPLES FOR THE SEAT TO MODULE ASSEMBLY APPLY TO BOTH THE SQUARE AND TRIANGLE MODULES, AND APPLY TO BOTH THE CURVED AND STRAIGHT SEAT SECTIONS

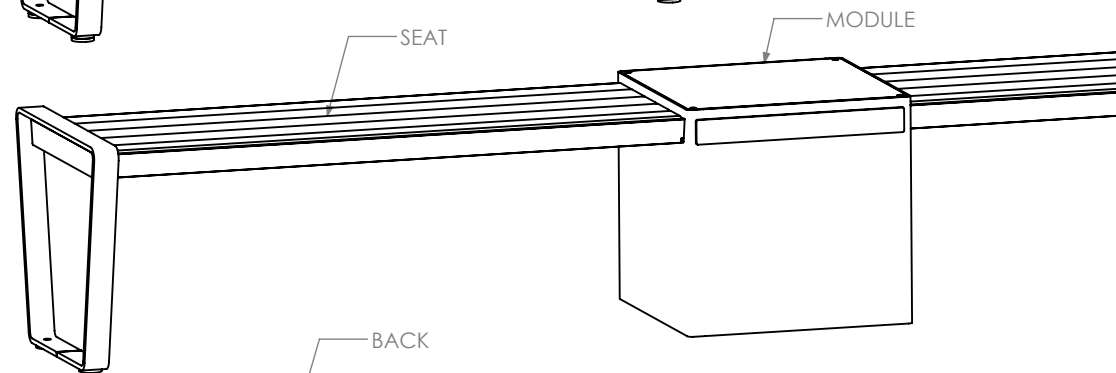

BACK TO SEAT (PG 11)

NOTE THE PRINCIPLES FOR THE BACK TO SEAT ASSEMBLY ARE APPLIED TO BOTH STRAIGHT AND CURVED SEAT SECTIONS.

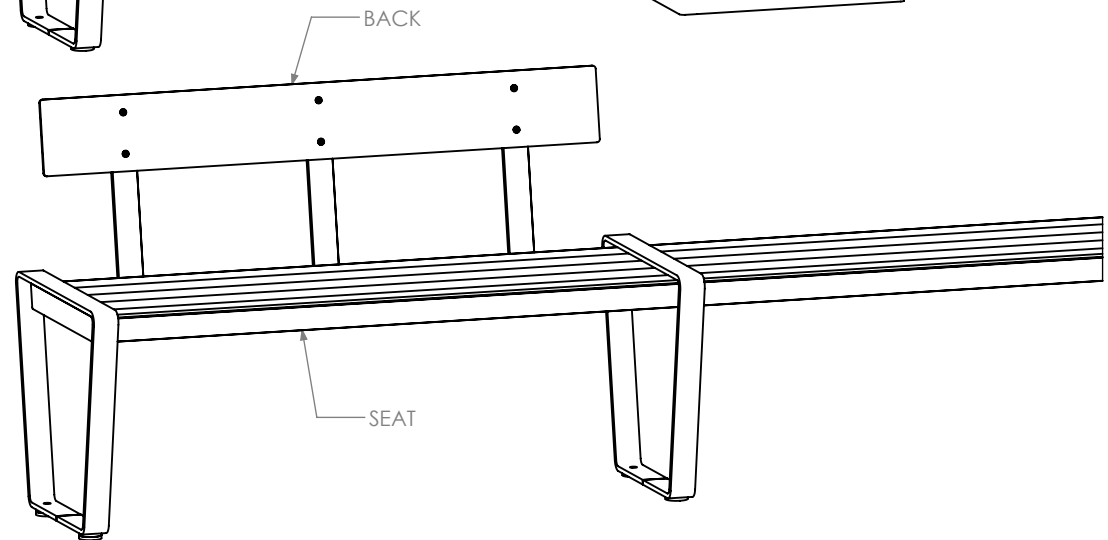

NOTES:

! CAUTION ! FAILURE TO FOLLOW INSTRUCTIONS COULD LEAD TO INJURY. ENSURE ALL STEPS ARE FOLLOWED AND FASTENERS ARE USED. TWO OR MORE PEOPLE ARE REQUIRED FOR INSTALLATION.

! CAUTION ! NOTE THAT THE ASSEMBLY HOOKS ARE DESIGNED TO ONLY AID IN THE ASSEMBLY PROCESS. PARTS SHOULD NOT BE LEFT UNATTENDED AND SHOULD BE BOLTED TOGETHER IMMEDIATELY AFTER PARTS ARE PLACED IN DESIRED LOCATION AS SEATING IS NOT SAFE FOR USE UNTILL FULLY FASTENED TOGETHER AND ANCHORED DOWN.

! CAUTION ! ALL ASSEMBLIES REQUIRE ADEQUATE ANCHORING TO AN APPROPRIATE SUBSTRATE. DO NOT LEAVE BENCH FREE STANDING. IT IS THE INSTALLERS RESPONSIBILITY TO USE APPROPRIATE ANCHORS AND IDENTIFY AN APPROPRIATE SUBSTRATE

TOOLS:

*NOTE TOOLS ARE NOT SUPPLIED



WRENCH
9/16"

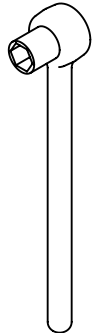

RATCHET WRENCH
9/16" SOCKET



ALLEN KEY
5/32"
(ONLY REQUIRED FOR MODULES)

FASTENERS:

QUANTITIES VARY FOR EACH PART. NOTE PROPER QUANTITIES REQUIRED IN EACH STEP.

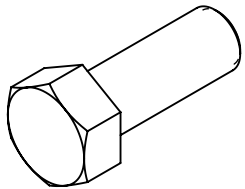

HEX BOLT
3/8" - 1 1/4"

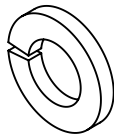

LOCK WASHER
3/8"

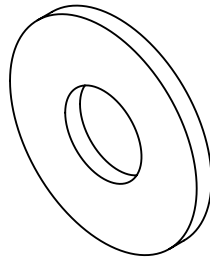

FLAT WASHER
3/8"

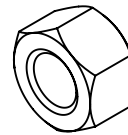

HEX NUT
3/8"

SEAT TO LEG

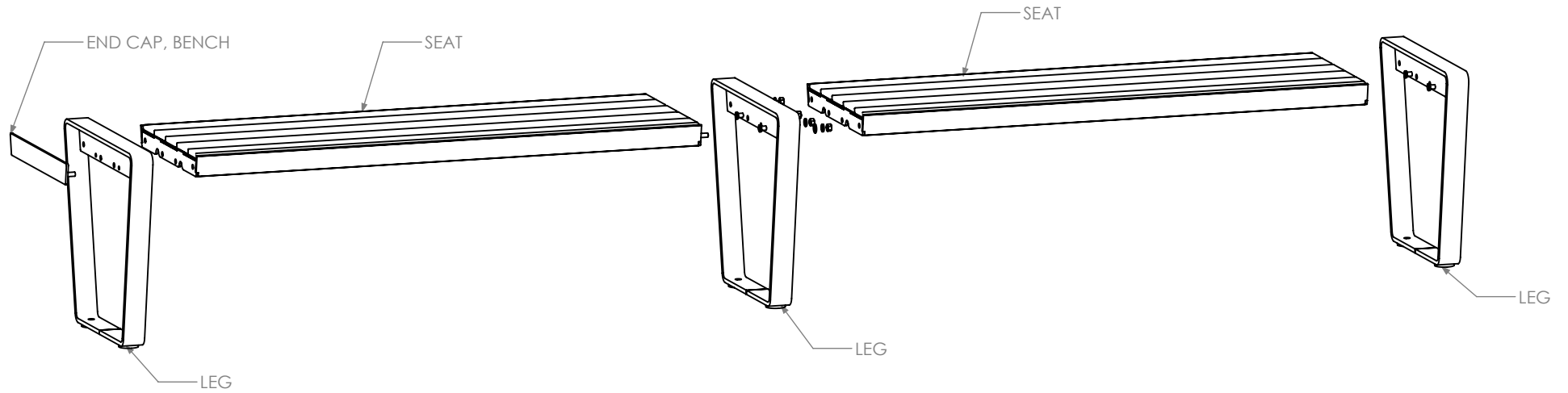

1

IDENTIFY A STARTING POINT OF THE BENCH ASSEMBLY.

IF ASSEMBLY STARTS WITH A LEG, SLIDE THE BENCH END CAP THRU THE LEG HOLES (DETAIL A)

IF ASSEMBLY STARTS WITH A MODULE SEE THE SEAT TO MODULE INSTRUCTIONS

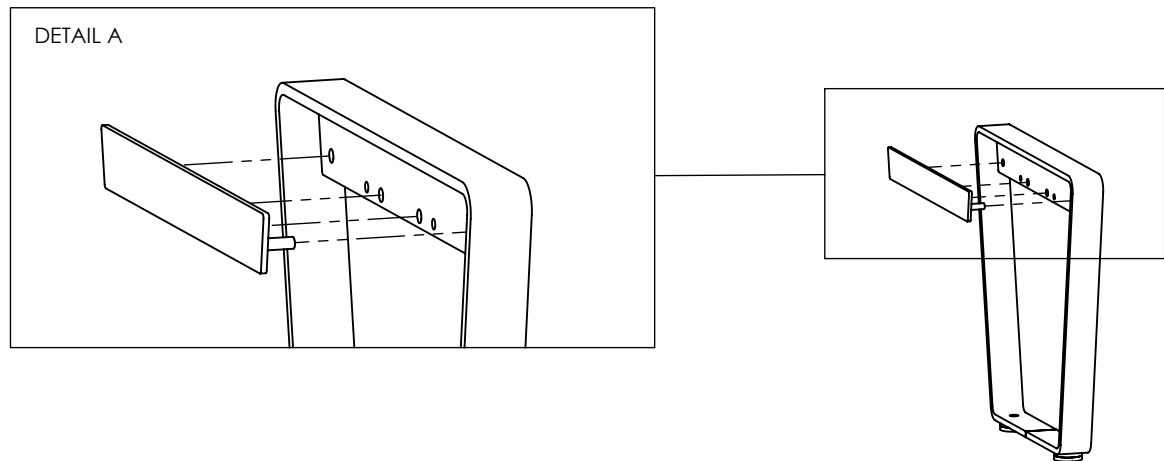

2 AS ONE PERSON HOLDS LEG AND END CAP IN PLACE A SECOND PERSON CAN TAKE THE SEAT SECTION AND ALIGN THE HOLES TO THE THREADED POSTS (DETAIL B)

STEPS 2-3 CAN BE DONE WITH BENCH SECTION UPSIDE-DOWN IF A PROTECTIVE SURFACE IS AVAILABLE SUCH AS CARDBOARD OR A BLANKET

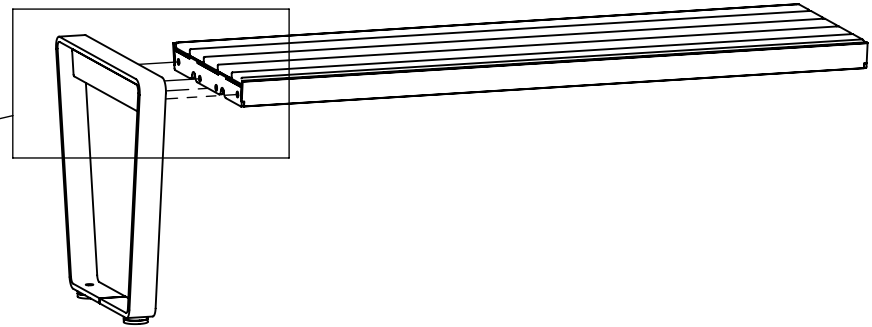
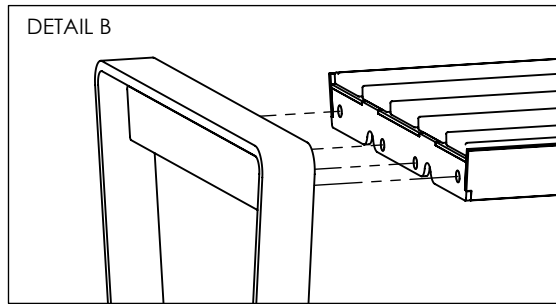

3 WITH THE END CAP THREADED POSTS FEEDING THROUGH THE LEG AND SEAT SECTION, PLACE FLAT WASHER, LOCK WASHER AND NUTS ON ALL 4 THREADED RODS (DETAIL C)

ENSURE ALL FASTENERS ARE FIRMLY FASTENED DOWN

ONCE TOGETHER, THE SUB-ASSEMBLY CAN BE HELD BY ONE PERSON (POINT D) WHILE THE OTHER RETRIEVES ANOTHER LEG

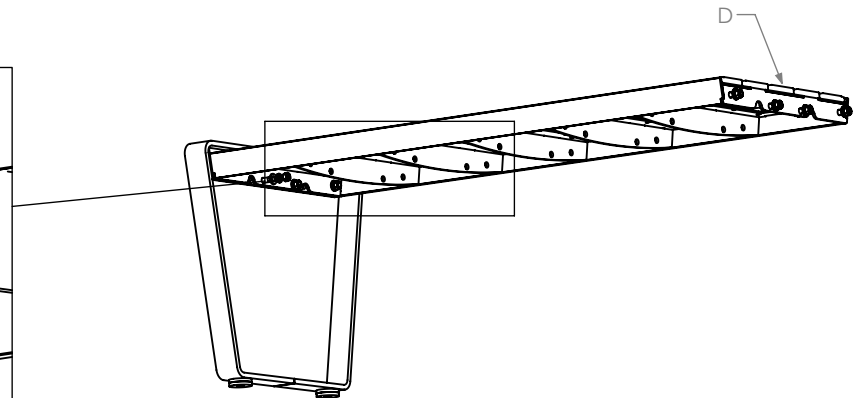
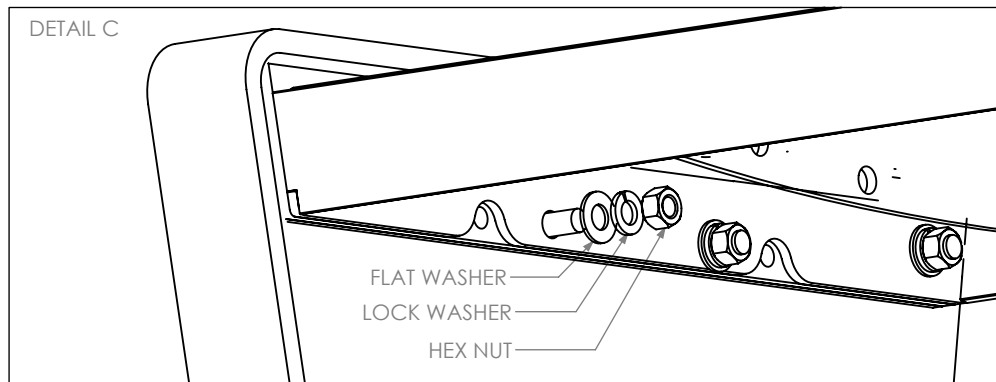

4

WITH OTHER LEG IN HAND USE HOOKS TO TEMPORARILY HOLD SEAT IN PLACE

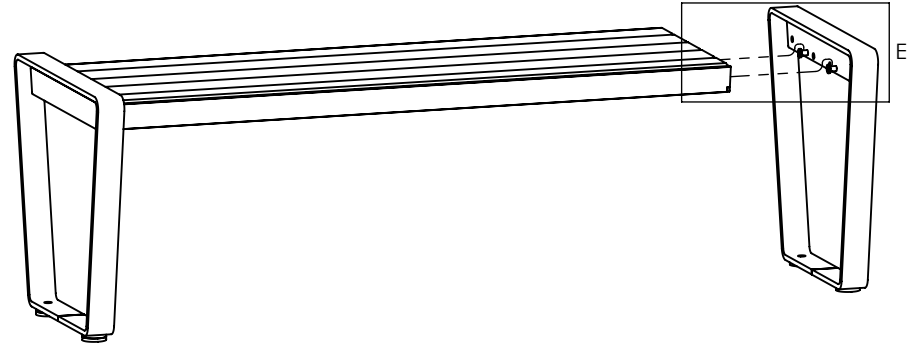
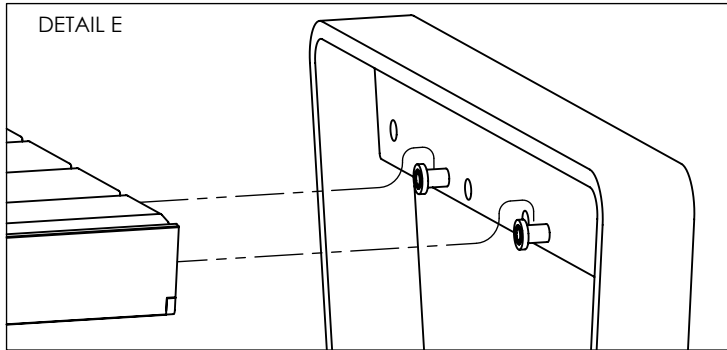

5

IF APPLICABLE, ATTACH NEXT SEAT SECTION WITH TWO PEOPLE

USE HOOKS ON OPPOSITE SIDE TO TEMPORARILY HOLD SEAT IN PLACE, AS ONE PERSON HOLDS WEIGHT ON SIDE WITHOUT LEG (POINT G)

THE SECOND PERSON CAN NOW TEMPORARILY PLACE THE OTHER LEG USING THE ASSEMBLY ASSIST HOOKS AT (POINT G)

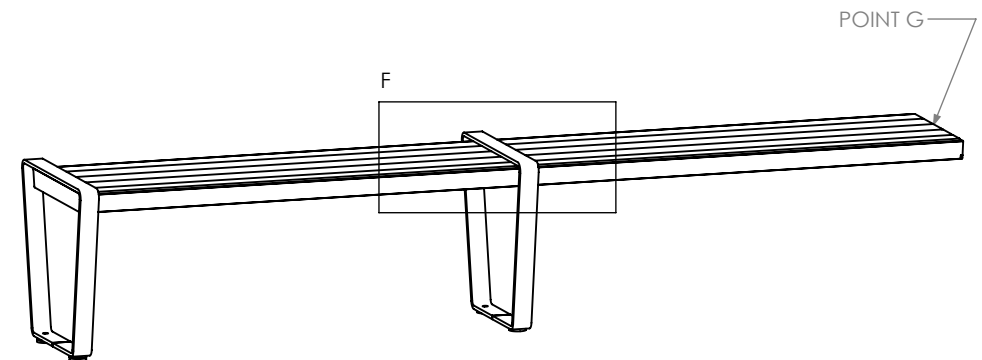
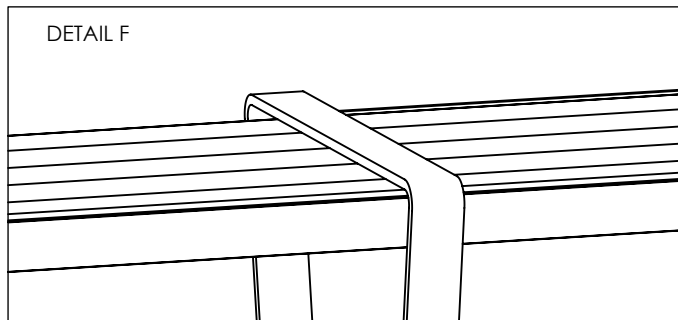

6

WITH THE SEAT TEMPORALLY IN PLACE THE TWO SEAT SECTIONS CAN BE SECURELY FASTENED TOGETHER USING A BOLT AND FLAT WASHER ON ONE SIDE AND A FLAT WASHER LOCK WASHER AND NUT ON THE OTHER SEE (DETAIL H)

ENSURE ALL 4 HOLES HAVE FASTENERS AND ARE FIRMLY FASTENED TOGETHER

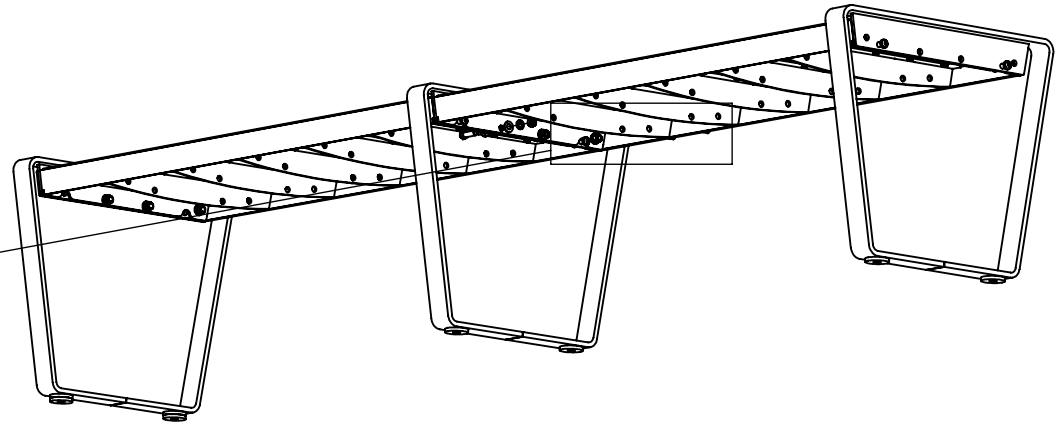
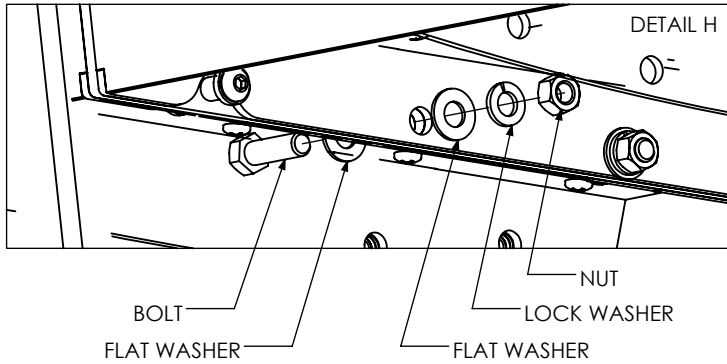

7

DEPENDING ON THE FINAL DESIGN LAYOUT CONTINUE USING THE SAME STEPS 4-6 IF MORE SEAT SECTIONS ARE TO BE ASSEMBLED

IF THIS IS THE END OF THE ASSEMBLY USE THE SAME PRINCIPLES OUTLINED IN STEPS 1-3

ONCE FULLY ASSEMBLED ENSURE BENCH IS LEVEL. SHIM IF NECESSARY (DETAIL I) AND ANCHOR BENCH WITH APPROPRIATE ANCHORS (NOT SUPPLIED) TO APPROPRIATE SUBSTRATE USING AVAILABLE 2 X 9/16" HOLES PER LEG

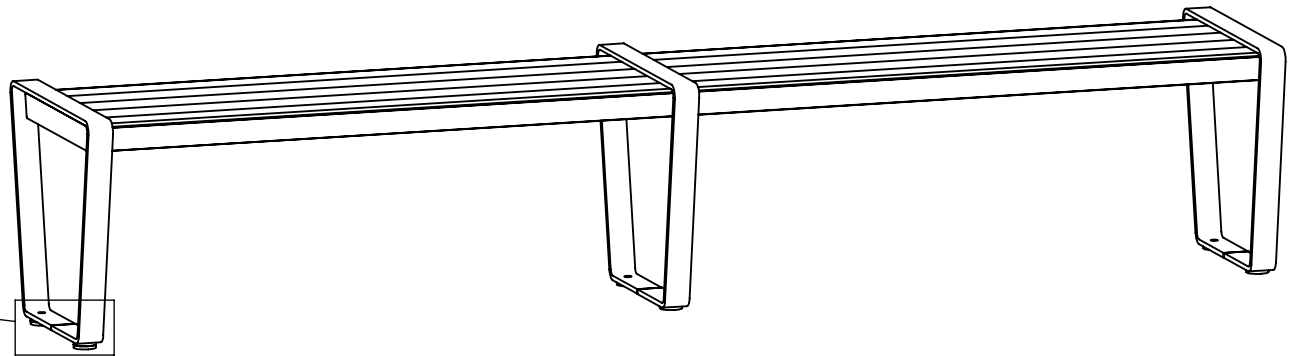
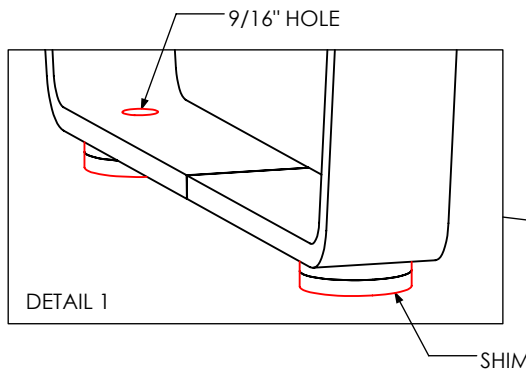

SEAT TO MODULE

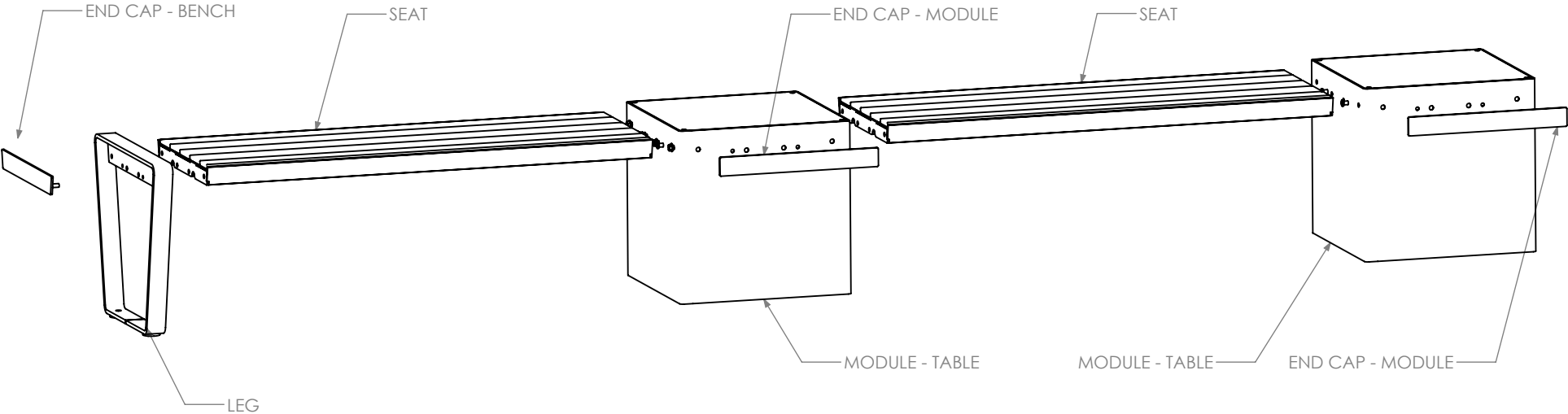

1 PLACE MODULE IN DESIRED LOCATION. REMOVE TOP TO ACCESS ASSEMBLY HOLES USING 5/32 ALLEN KEY. FOR PLANTERS ALSO REMOVE LINER TO ACCESS ASSEMBLY AND ANCHORING HOLES

BOLT AN END CAP ON ALL SIDES THAT WILL NOT HAVE A SEAT ATTACHED. USE 2 X FLAT WASHERS, 2 X LOCK WASHERS, 2 X NUTS PER END CAP. NOTE END CAPS DISTANCE FROM TOP EDGE (DETAIL A)

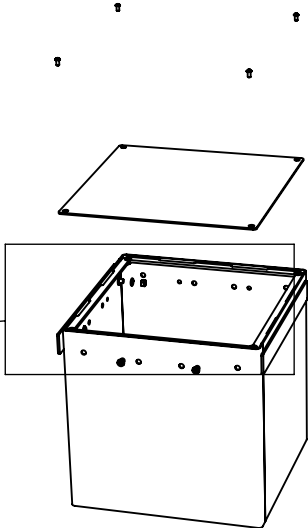
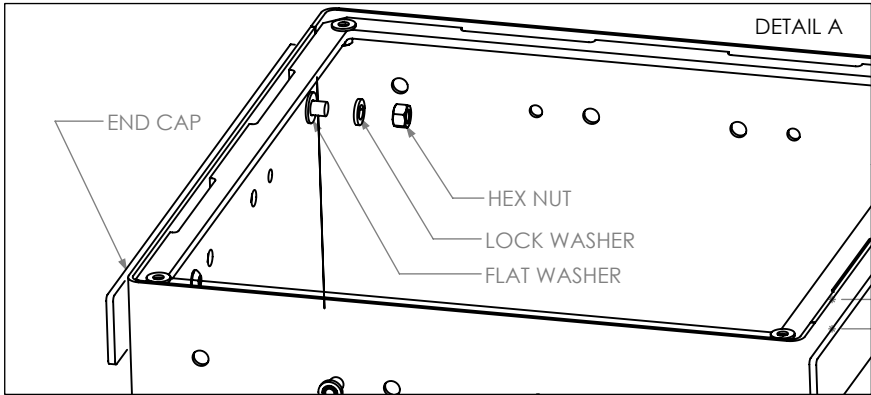

- 2** LEAVE COVER OFF UNTIL FULL ASSEMBLY IS COMPLETE
 REFERENCING THE SEAT TO LEG ASSEMBLY
 INSTRUCTIONS. USE HOOKS TO ADD NEXT SECTION

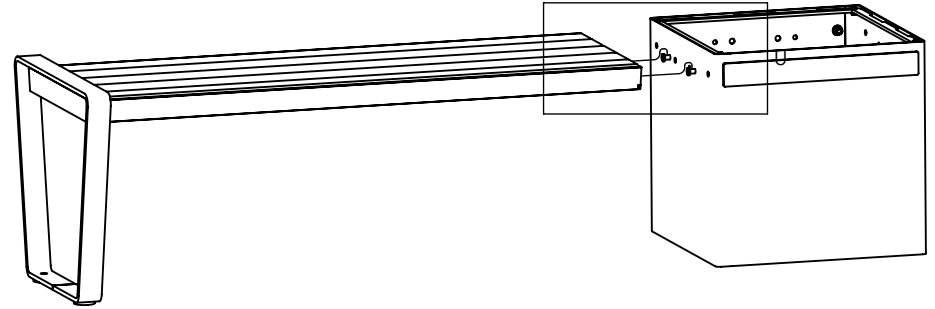
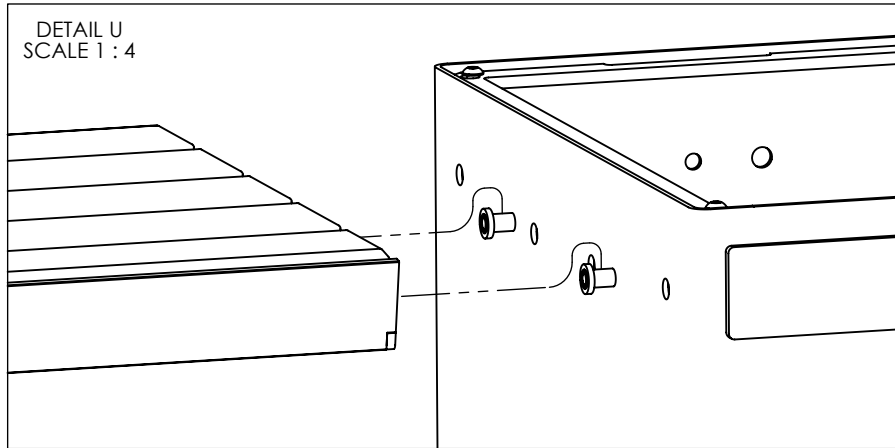

- 3** BOLT SEAT SECTION TO MODULE WITH 4 X BOLTS, 8 FLAT
 WASHERS (USE ON BOTH SIDES OF MODULE), 4 X LOCK
 WASHERS AND 4 X HEX NUTS (DETAIL B AND C)
 REFERENCING THE SEAT TO LEG. USE HOOKS TO ADD
 NEXT SECTION

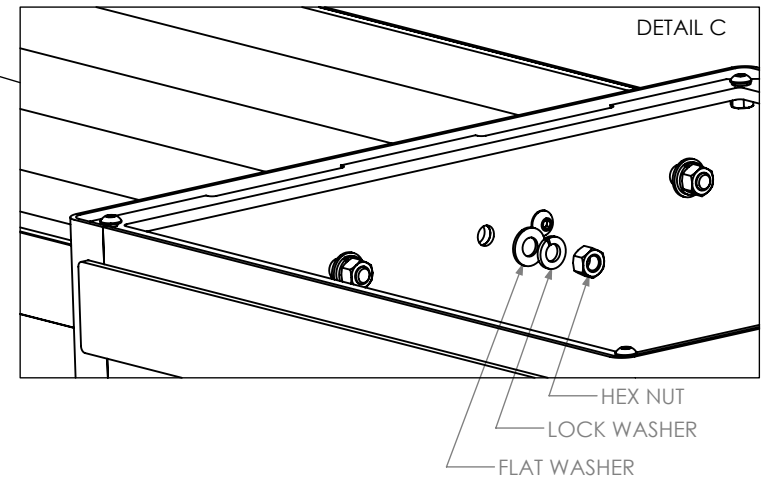
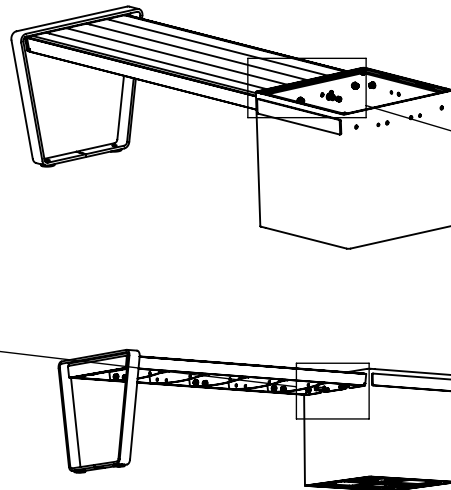
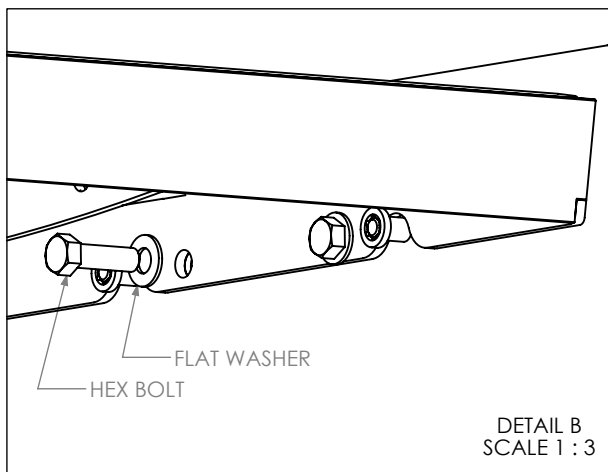

4

IF AN ADDITIONAL PLANTER IS PART OF THE ASSEMBLY PLACE IN DESIRED LOCATION AND PLACE BENCH SECTION ON HOOKS.

BOLT TOGETHER FOLLOWING PROCEDURES IN STEPS 1-3

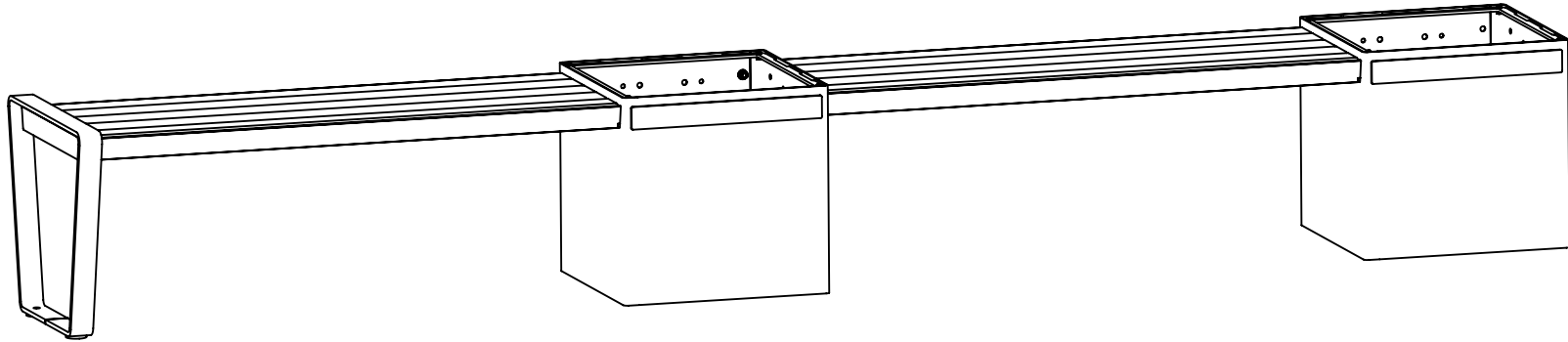

5

ONCE FULLY ASSEMBLY IS BOLTED TOGETHER AND IN FINAL DESIRED LOCATION BOLT MODULES TO THE GROUND. USE APPROPRIATE ANCHORS FOR FASTENING (NOT SUPPLIED). BOLT ALL LEGS IN SAME MANNER IF APPLICABLE.

IF PARTS ARE NOT TOUCHING THE GROUND OF NEED LEVELING SHIM AS NEEDED PRIOR TO BOLTING.

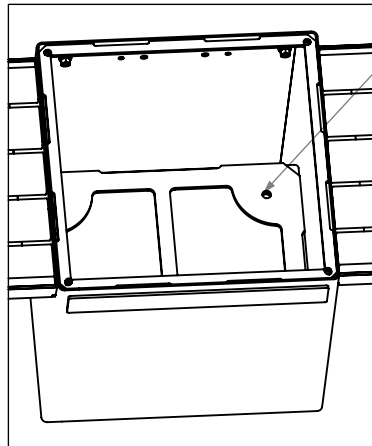

ANCHOR HERE
4X HOLES SQUARE MODULE
3 X HOLES TRIANGLE MODULE

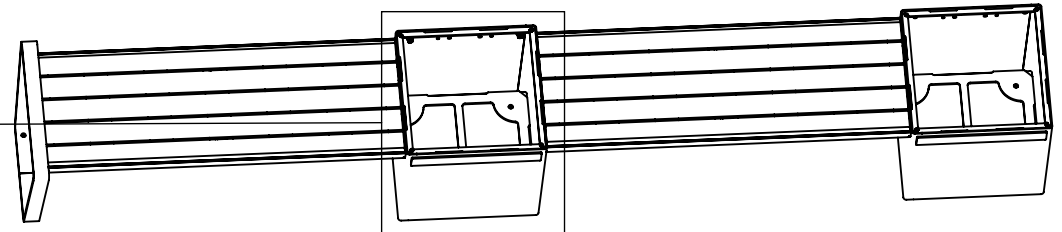

6 RETURN COVERS TO MODULES USING 5/32" ALLEN KEY AND 1/4" PAN HEAD HEX FASTENERS

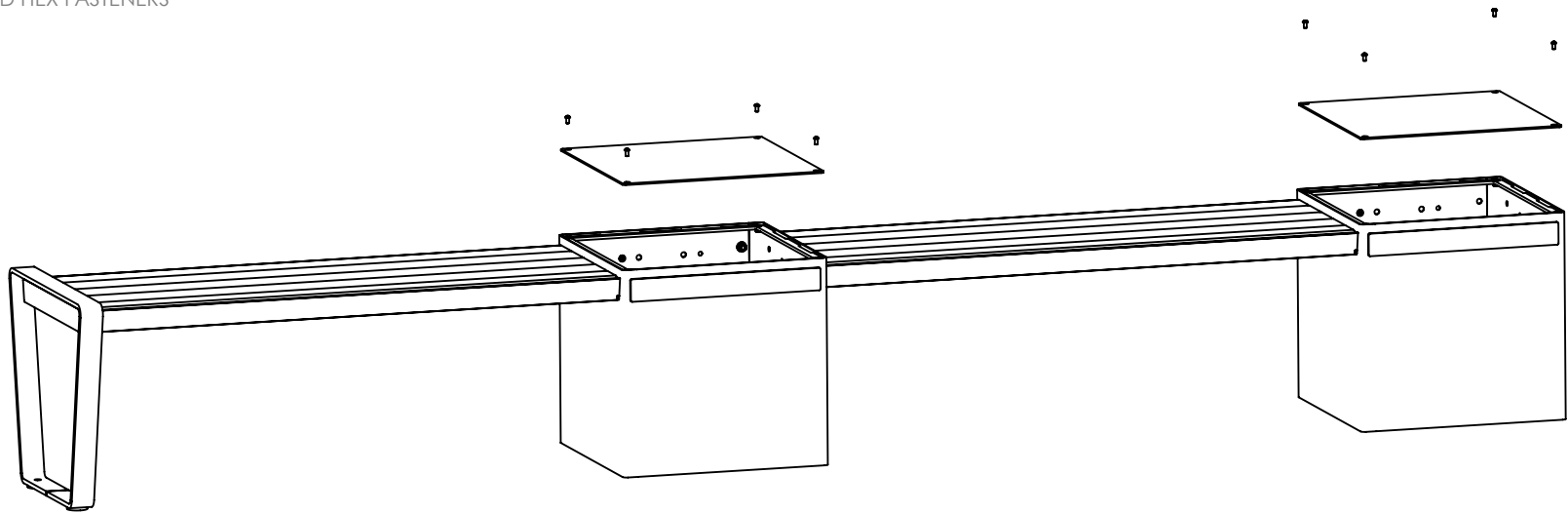

7 ASSEMBLY IS NOW COMPLETE

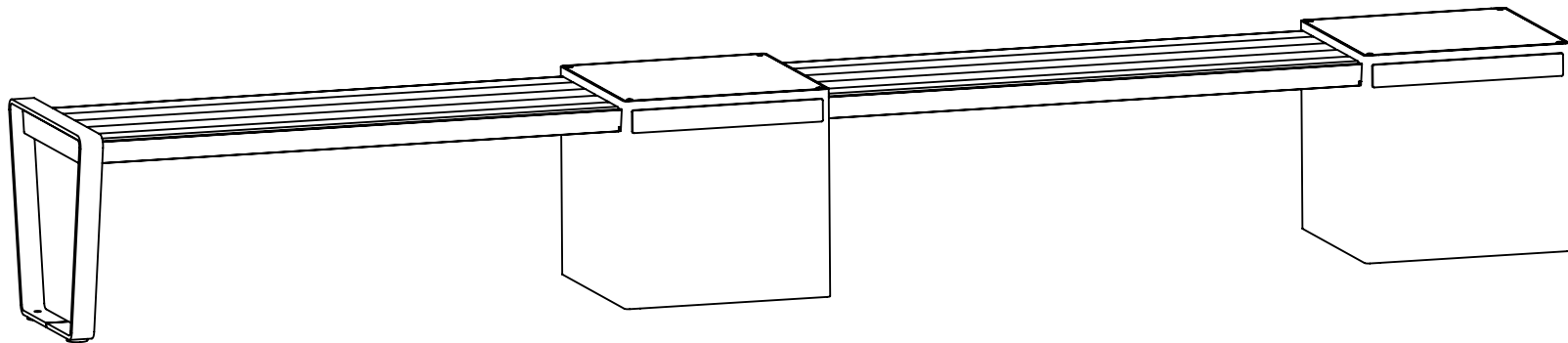

BACK TO SEAT

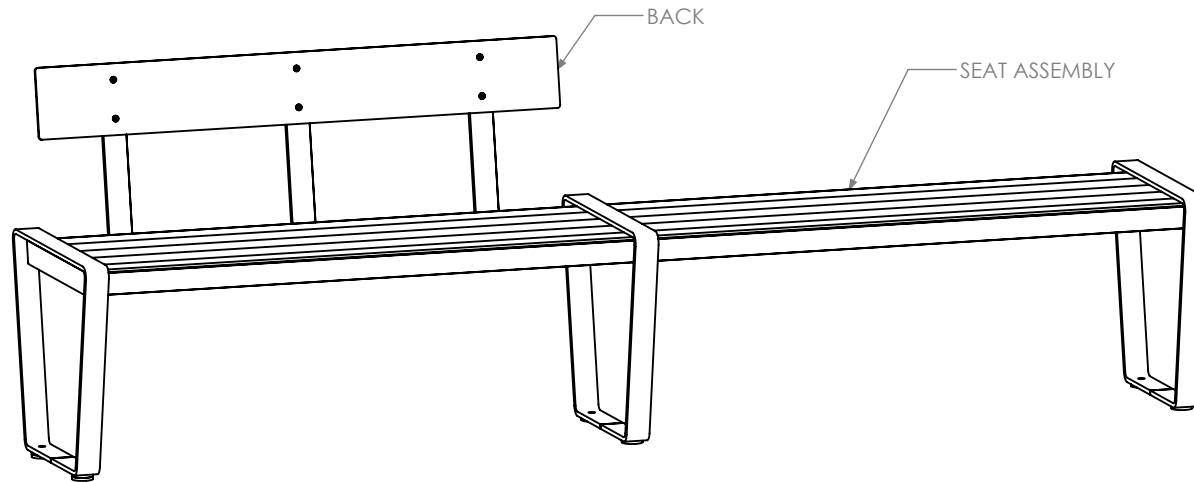

1

CAUTION ENSURE SEAT, LEGS AND MODULES ARE BOLTED TOGETHER PRIOR INSTALLING BACKS.

REFERENCE THE BENCH TO BENCH AND BENCH TO MODULE ASSEMBLY STEPS TO PRE ASSEMBLE ALL LAYOUT SECTIONS FIRST WITHOUT ANY BACKS.

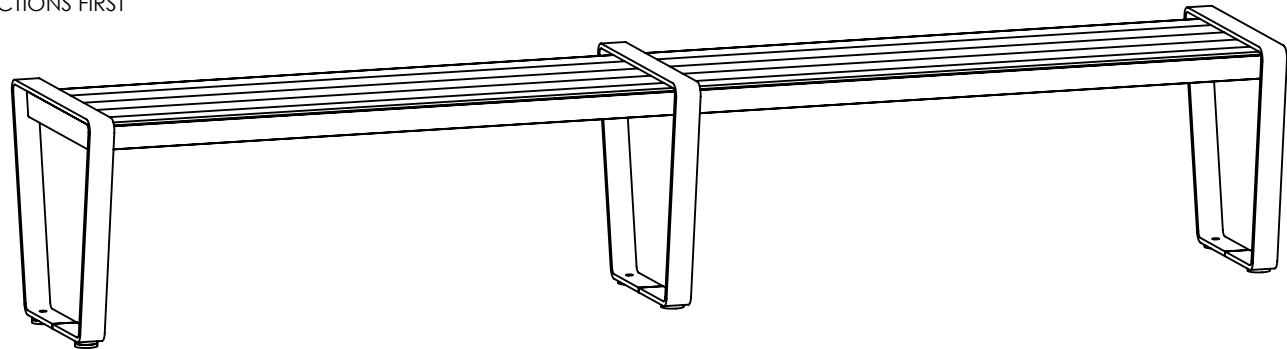

2 IDENTIFY SECTIONS(S) WHERE BACKS ARE TO BE INSTALLED AND TAKE NOTE OF WHERE THE THREADED POSTS ARE (DETAIL A)

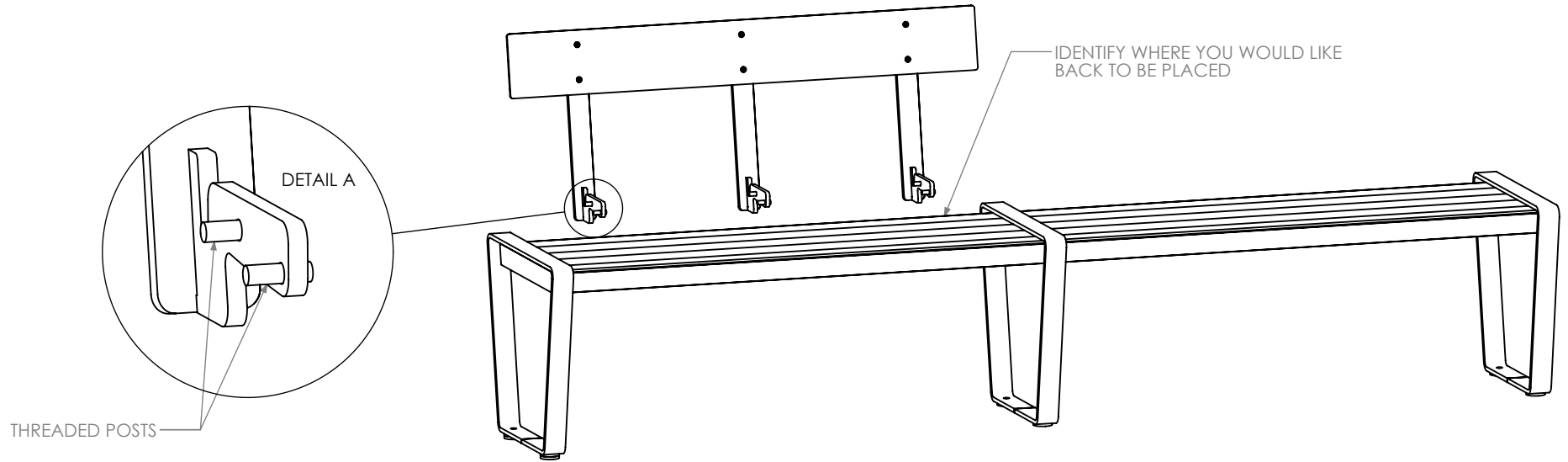

3 WITH ONE PERSON HOLDING THE WEIGHT OF THE BACK, HAVE A SECOND PERSON ALIGN THREADED POSTS ON BACK WITH THE 2 HOLES UNDER THE BENCH (POINT Z)

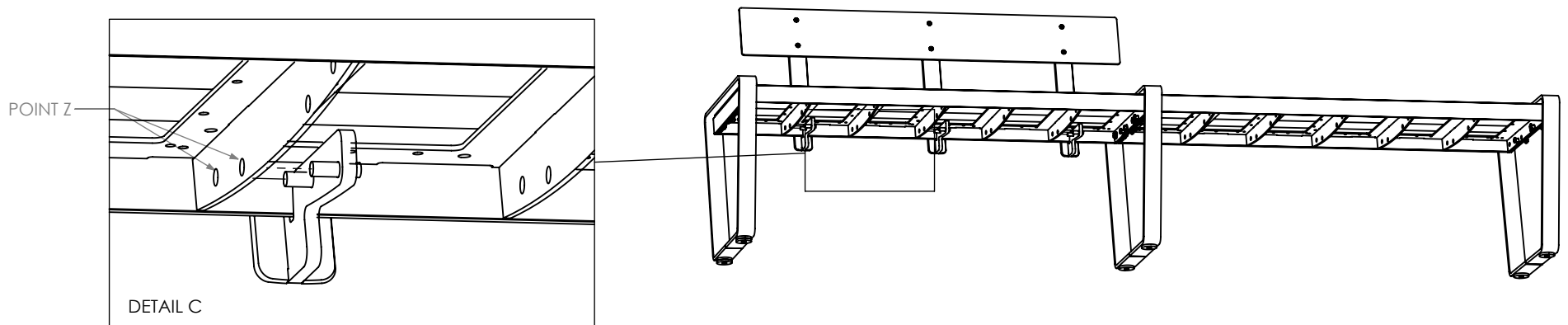

4

ENSURE ALL 6 THREADED RODS HAVE GONE THROUGH HOLE UNDER SEAT FRAME.

USING 6 X FLAT WASHERS, 6 X LOCK WASHERS AND 6 X HEX NUTS FIRMLY SECURE BACKREST TO THE SEAT SECTION.

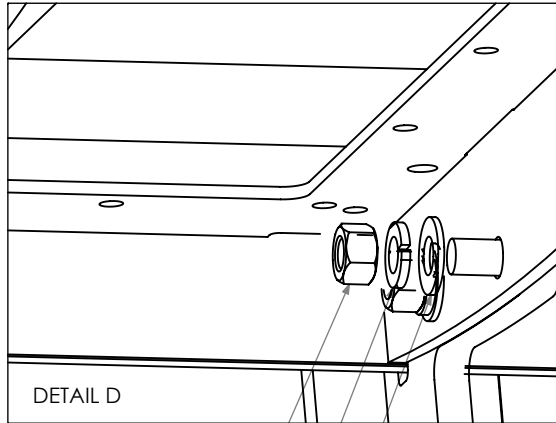

HEX NUT
LOCK WASHER
FLAT WASHER

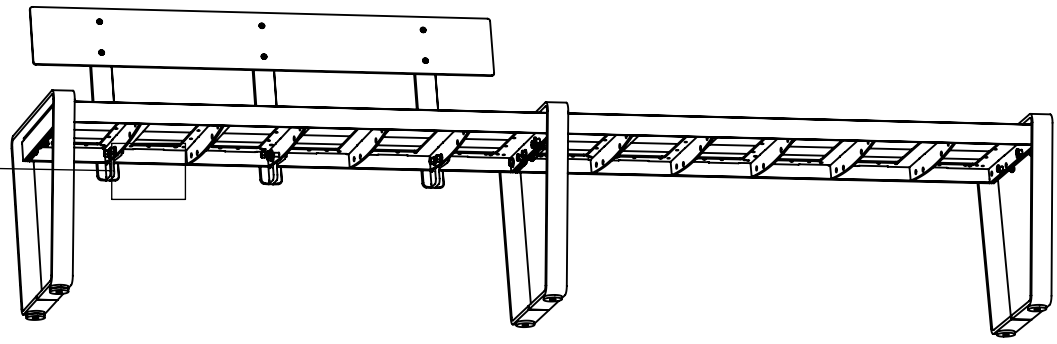

5

BACK ASSEMBLY NOW COMPLETE. APPLY STEPS TO ALL OTHER BACKS THAT REQUIRE ASSEMBLY

